

# Washer-Extractor

## SP Series Installation and Operation Manual

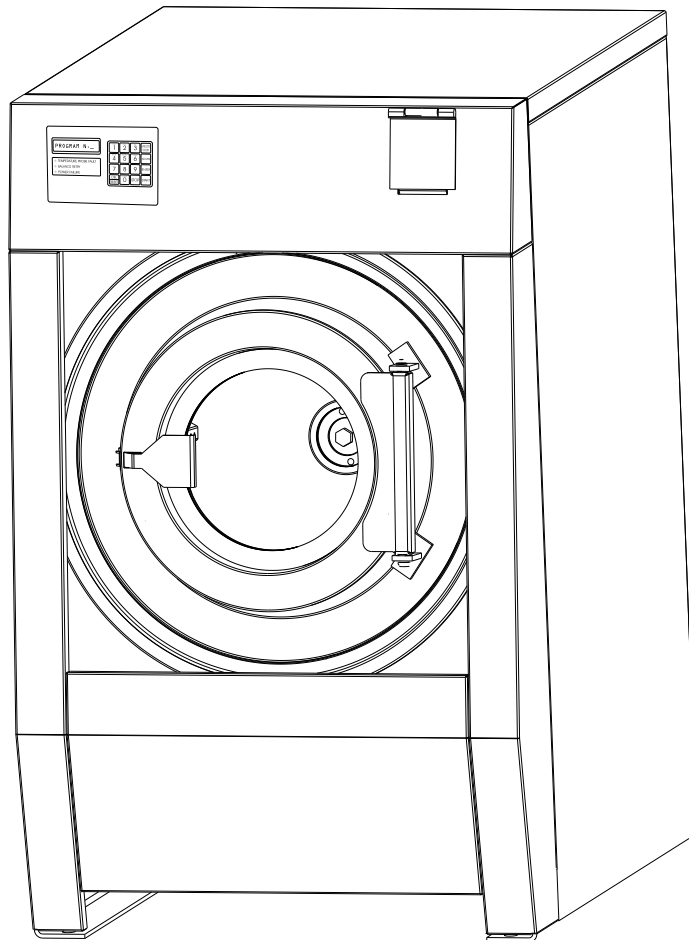

### B&C Technologies

Panama City, FL

(850) 249-2222

(850) 249-2226 FAX

[www.bandctech.com](http://www.bandctech.com)

### Accurate Technologies

Samutprakarn, Thailand

+66 (0) 2740-5511

+66 (0) 2740-5522 FAX

[www.accuratethai.com](http://www.accuratethai.com)

Revision 2.0

19-Jul-2007



# Table of Contents

Introduction	
Customer Service	3
Replacement Parts	3
General Specifications	4
Safety Information	5
Key Symbols	5
Safety Checklist	6
Installation	
Theory of Operation	11
Inspection and Uncrating	13
SP-40 Technical Specs	14
SP-60 Technical Specs	16
SP-100 Technical Specs	18
Dimensional Clearance	20
Foundation	21
Drain Connection	25
Electrical Installation	26
Water Connection	28
Steam Connection	29
External Chemicals	30
Function Test	33
Operation	34
Routine Maintenance	41
Decommissioning	45

## B&C Technologies

Panama City, FL  
(850) 249-2222  
(850) 249-2226 FAX  
[www.bandctech.com](http://www.bandctech.com)

## Accurate Technologies

Samutprakarn, Thailand  
+66 (0) 2740-5511  
+66 (0) 2740-5522 FAX  
[www.accuratethai.com](http://www.accuratethai.com)

# SP Model Family Options

B&C Technologies / Accurate Technologies

<b>Family</b>	<b>Capacity</b>	<b>Control</b>	<b>Voltage</b>	<b>-</b>
SP	40	E-EL6	2 - 200-240V, 50/60Hz, 3ph	
	60	I-Insight	4 - 380-415V, 50/60Hz, 3ph	
	100		5 - 440-480V, 50/60Hz, 3ph	

<b>Fills</b>	<b>Dispenser</b>	<b>Drains</b>	<b>Heat</b>	<b>Prep</b>	<b>-</b>
1 - Cold	1 - 1 Cup	A - 1 Rear	N - None	N - None	
2 - Cold, Hot	5 - 5 Cup	B - 2 Rear	E - Electric	F - EMI Filter	
3 - Cold, Hot, Aux			S - Steam		

<b>Approvals</b>	<b>Packing</b>	<b>Design Rev.</b>
A - USA	B - Bag	A
E - Europe	C - Crate	
N - None		

SP-40-E2-21ANN-ABA

Design Rev.  
Packing  
Approvals  
Prep  
Heat  
Drains  
Dispenser  
Fills  
Voltage  
Control  
Capacity  
Family

# Introduction

## SP Series Washer-Extractors

The B&C SP line is the professional freestanding washer-extractor series of machines from B&C Technologies. It is an open pocket washer-extractor with a large door opening for easy and quick loading and unloading. It has been developed for the on premise market, and is suitable for commercial laundries, hotel and other places where laundry might be processed

The design allows for top performance at lowest possible operation cost and investment. The flexible electronic control center ensures that maximum productivity is obtained.

The SP series utilizes high quality material, such as 304 (18/8) stainless steel in vital parts in contact with the wash solution. It has a stainless steel cabinet for long life with easily removable panels.

The key advantages of this series are the simplicity of the microprocessor and the electronic AC drive system, which utilizes only one motor. The system allows for washing and extraction at any speed and mechanical action to suit any textile fiber used today and tomorrow. A built in suspension system isolate objectionable vibrations and the high speed final extraction saves time and energy in the finishing operation.

A single compartment supply dispenser for powder and liquid detergents is standard (five compartment optional) and the machine is designed to accept the connection of 8 additional external chemical lines and pumps.

The SP series is also prepared to accept the connection of water reuse systems. These systems can be installed separate or on top of the machine. They are available in either single or dual tanks for

maximum savings of water up to 40%. The tanks can be equipped with or without steam or electrical heat depending on installation and operation. The water reuse system is programmable by the machines electronic control center.

Wecleaning and Ozone integration are also possible with the SP series, making them the most flexible machine available today.

### Customer Service

For technical assistance, call the following number:

In the United States

Phone: (850)-249-2222

FAX: (850) 249-2226

e-mail: [techsupport@bandctech.com](mailto:techsupport@bandctech.com)

Web: [www.bandctech.com](http://www.bandctech.com)

In Thailand

Phone: +66 (0) 2740-5511

FAX: +66 (0) 2740-5522

e-mail: [sales@accuratethai.com](mailto:sales@accuratethai.com)

Web: [www.accuratethai.com](http://www.accuratethai.com)

### Replacement Parts

In the event that literature or replacement parts are required, contact the local distributor of the equipment, or contact B&C Technologies at the above phone numbers/internet addresses.

# Introduction

## General Specifications

	US	Metric	SP-40		SP-60		SP-100	
<b>Overall Dimensions</b>								
<b>A</b> - Width	inch	mm	35	890	39.5	1003	47	1194
<b>B</b> - Depth	inch	mm	43	1093	48.5	1232	54	1372
<b>C</b> - Height	inch	mm	56	1422	63.6	1615	70	1778
<b>Wash Cylinder Information</b>								
Diameter	inch	mm	26.8	680	31.1	790	37	940
Depth	inch	mm	20.3	515	22	560	27.2	690
Volume	cu ft	liters	6.6	187	9.7	274	16.9	478
Capacity, 1:10 fill ratio	lb	kg	41	18.7	60	27.4	105	47.8
<b>Door Opening</b>								
Door Opening Diameter	inch	mm	15.7	400	17.7	450	19	483
Height to bottom of door	inch	mm	23.2	588	26.5	672	28.6	728
<b>Drain System</b>								
Overflow Size	inch	mm	1.5	38.1	1.5	38.1	1.5	38.1
Drain Outlet Size	inch	mm	3	76.2	3	76.2	3	76.2
Number of Drain Outlets	standard	optional	1	2	1	2	1	2
<b>Water Inlet</b>								
Connection Size	NPT		3/4 NPT		3/4 NPT		1 NPT	
Number of Inlets	standard	optional	2	3	2	3	2	3
<b>Chemical Supply System</b>								
Number of Dry Chemical Compartments	standard	optional	1	5	1	5	1	5
Number of Liquid Supply Connections	standard	optional	6	8	6	8	6	8
Liquid Supply Connection Size	NPT		1/2 NPT		1/2 NPT		1/2 NPT	

**Note:** Wash and Extract speeds are fully programmable. The values shown are examples.

Our Policy is one of ongoing improvements. Specifications are subject to change without notice.

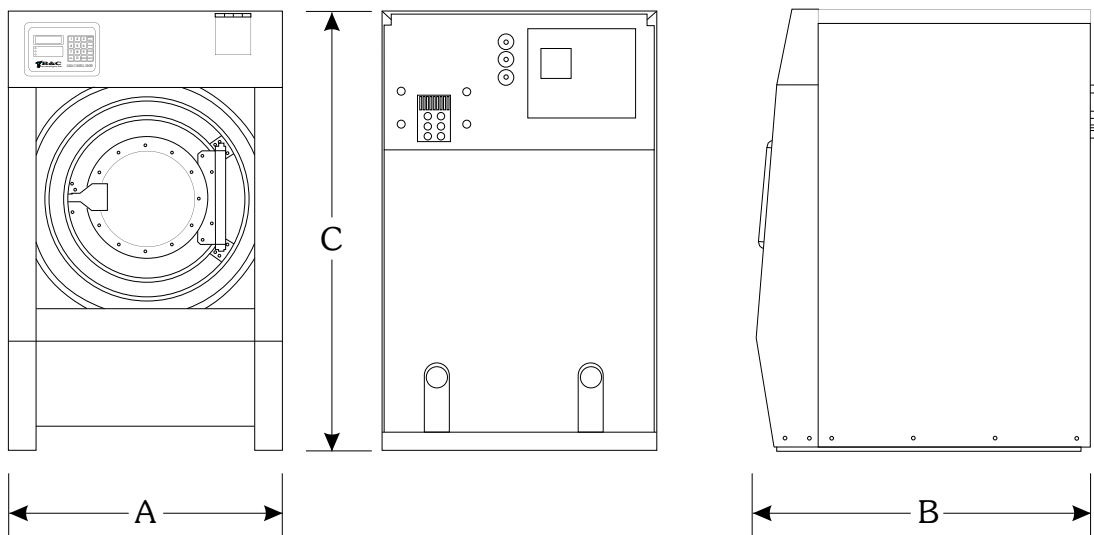

# Key Symbols

Anyone operating or servicing this machine must follow the safety rules in this manual. Particular attention must be paid to the DANGER, WARNING, and CAUTION blocks which appear throughout the manual



The lightning flash and arrowhead within the triangle is a warning sign alerting you of the presence of dangerous voltage.



This warning symbol indicates the presence of hot surfaces that could cause serious burns. Stainless steel and steam lines can become extremely hot and should not be touched.



The exclamation point within the triangle is a warning sign alerting you of important instructions concerning the machine and possible dangerous conditions.



This warning symbol indicates the presence of possible dangerous pinch-points. Moving mechanical parts can crush an/or sever body parts.



This warning symbol alerts you to the presence of possible dangerous drive mechanisms within the machine. Guards should always be in place when the machine is in operation. Be careful when servicing any drive mechanism.



Before servicing any equipment, make certain it is disconnected from the electrical power source. Never allow operation of the machine when any safety device is malfunctioning. Never bypass safety devices.



This warning symbol indicates the presence of possibly dangerous chemicals. Proper precautions should be taken when handling corrosive or caustic material.

# Introduction

## Safety Checklist

Before Initial start up of a B&C free-standing washer extractor perform the following safety check:

- A. Make sure all electrical and plumbing connections have been made in accordance with applicable codes and regulations.
- B. Make sure the machine is grounded electrically.
- C. Make sure the machine has flexible water fill and drain connections of the correct size, length and type, with no kinks, and that they are securely attached and/or clamped.
- D. Make sure the transport brackets have been removed.

Before machine is placed in operation, the door safety interlock must be checked for proper operation as follows:

- A. When the washer is energized electrically and in operation, the loading door must be locked in the closed position. Verify this by attempting to open the loading door when the machine is operating. If necessary, check the door safety interlock and sensors for proper operation. Consult the service manual, or call a qualified service technician if necessary.
- B. When the washers loading door is open, it should not be possible to start the machine. Verify this by attempting to start the washer with the door open. Also, close the door without locking it and verify

that it is not possible to start the machine with the door not locked. If necessary, check the door lock sensors for proper operation,. Consult the service manual, or call a qualified service technician. If additional information is required, contact your local distributor or call the manufacturer of the machine.



Before servicing any equipment, make certain it is disconnected from the electrical power source. Never allow operation of the machine when any safety device is malfunctioning. Never bypass safety devices.

# Introduction

## Safety Checklist

To provide personal safety and keep the machine in proper working order, follow all maintenance and safety procedures presented in this manual. If questions regarding safety arise. Contact the factory immediately.

Use factory authorized spare parts to avoid safety hazards.

### Operator safety



Never insert hands or objects into basket until it has completely stopped. Doing so could result in serious injury

3.2 Excessively high water level is evident.

3.3 Machine is not connected to a properly grounded circuit.

Do not bypass any safety devices in the machine.



Never operate the machine with a bypassed or disconnected out-of-balance switch. Operating the machine with severe out-of-balance loads could result in personal injury and serious equipment damage.

To ensure the safety of machine operators the following maintenance checks must be performed daily.

1. Prior to operating the machine, verify that all warning signs are present and legible. Missing or illegible signs must be replaced immediately. Make certain that spares are available.

2. Check door interlock before starting operation of the machine, see safety check list.

3. Do not attempt to operate the machine if any of the following conditions are present:

3.1 The door does not remain securely locked during the entire cycle.

# Introduction

## Safety Checklist

### Safe Operation Environment

Safe operation requires an appropriate operating environment for both the operator and the machine. If questions regarding safety arise, contact the factory.

### Environmental Conditions

1. Ambient temperature. Water in the machine will freeze at temperatures of 32F (0C) or below. Temperatures above 120 F (50C) will result in more frequent motor overheating and, in some cases, malfunction or premature damage to solid state devices that are used in the machines. Special cooling devices may be necessary.

2. Humidity. Relative humidity above 90% may cause the machine's electronics or motors to malfunction or may trip the ground fault interrupter. Corrosion problems may occur on some metal components. If the relative humidity is below 30% belts and rubber hoses may eventually develop dry rot. This condition can result in hose leaks, which may cause hazards external to the machine in conjunction with adjacent electrical equipment.

3. Ventilation. The need for make-up air openings for such laundry room accessories as dryers, ironers, water heaters, etc. must be evaluated periodically. Louvers, screens, or other separating devices may reduce the available air opening significantly..

4. Radio Frequency Emissions. A filter is available for machines in installations

where floor space is shared with equipment sensitive to radio frequency emissions. All machines that are shipped to CE countries are equipped with this filter and comply with the EMI regulations.

5. Elevation. If the machine is to be operated at elevations over 3280 feet (1000 meters) above sea level, pay special attention to water levels and electronic settings (particularly temperature) or desired result may not be achieved.

6. Chemicals. Keep stainless steel surfaces free of chemical residues to avoid corrosion.

7. Water damage. Do not spray the machine with water. Short circuiting and serious damage may result. Repair immediately all seepage due to faulty gaskets, etc.



Do not place volatile or flammable fluids in any machine. Do not clean the machine with volatile or flammable fluids such as acetone, lacquer thinners, enamel reducers, carbon tetrachloride, gasoline, benzene, naphtha, etc. Doing so could result in serious personal injury and/or damage to the machine.

### Machine Location

1. Foundation. The concrete floor must be of sufficient strength and thickness to handle the floor loads generated by the machine at high extract speeds.

# Introduction

## Safety Checklist

2. Service/ Maintenance Space. Provide sufficient space to allow comfortable performance of service procedures and routine maintenance. This is especially important in connection with machines equipped with AC inverter drives. Consult installation instructions for specific details.

Replace all panels that are removed to perform service and maintenance



procedures. Do not operate the machine with missing guards or with broken or missing parts. Do not bypass any safety devices

### Input and output

#### services

1. Water pressure. Best performance will be realized if water is provided at a pressure of 30-85 psi (2.0-5.7 bar). Although the machine will function properly at lower pressure, increased fill time will occur. Water pressure higher than 120 psi (8.0 bar) may result in damage to machine plumbing, components failure (s) and personal injuries.

2. Optional Steam heating pressure. Best performance will be realized if steam pressure is provided at a pressure of 30-80 psi (2.0-5.4 bar). Steam pressure higher than 125 psi (8.5 bar) may result in damage to steam components and may cause personal injuries. For machines equipped with optional steam heat, install piping in accordance with approved commercial steam practices. Failure to

install a steam filter may void the warranty.

3. Drainage System. Provide drain lines or troughs large enough to accommodate the total quantity of water that could be dumped if all machines on the site drained at the same time from the highest attainable level. If drain troughs are used, they should be covered to support light foot traffic

4. Power. For personal safety and for proper operation, the machine must be grounded in accordance with state and local codes. The ground connection must be to a proven earth ground, not to conduits or water pipes. An easy-access disconnect switch should be provided.

Ensure that a ground wire from a proven earth ground is connected to the ground lug in the electrical junction box on this machine. Without proper grounding personal injury from electrical shock could occur and machine malfunctions may be evident. Computer-controlled machines must have a proper ground to prevent computer malfunctions.



Always disconnect power and water supplies before a service technician performs any service procedure. Where applicable, steam and/or compressed air supplies should also be disconnected before service is performed

# Introduction

## Safety Checklist

### AC Inverter Drive

Machines equipped with AC drives require special attention with regard to the operating environment.

1. An especially dusty or linty environment will require more frequent cleaning of the AC drive cooling fan filter and of the AC drive itself.
2. Power line fluctuations from sources such as an uninterruptible power supplies (UPS) can adversely affect machines equipped with the AC drive. Proper suppression devices should be utilized on the incoming power to the machine to avoid problems.
3. A clean power supply free from voltage spikes and surges is absolutely essential for machines equipped with the AC drive. Nonlinear inconsistencies (peaks and valleys) in the power can cause the AC drive to generate nuisance errors. If voltage is above 230V for 200 V installations or above 460V for 400V installations, a buck/boost transformer is recommended. If voltage is above 240V or 480V, a buck/boost transformer is required unless the factory advises differently.
4. Sufficient space to perform service procedures and routine preventive maintenance is especially important for machines equipped with AC drives.

### Misuse

Even though this machine is an atmospheric vessel, never use it for any purpose other than washing fabrics.

1. Never wash petroleum-soaked rags in the machine. This could result in an explosion
2. Never wash machine parts or automotive parts in the machine. This could result in serious damage to the basket.
3. Never stone wash in the machine. It could wear the basket and serious damage might occur to the machine.
4. Never use the machine for dyeing and with harsh chemicals that can cause corrosion and other health hazards.
5. Never allow children to play on or around this machine. Death or serious injury can result if children become trapped in the machine. Do not leave children unattended while the machine door is open. these cautions apply to animals as well.

# Installation

## Theory of Operation

The B&C SP models use a single-speed motor to drive the cylinder via V-belts in all speeds. The cylinder is supported by two spherical roller bearings located in split pillow block housings made of cast steel.

The motor is controlled by the computer control located in the front and the AC inverter drive located in the rear panel. Any speed can be programmed for any wash cycle. Some speed ranges are blocked out for programming due to safety reasons. These speed ranges are the ones that the machine cannot operate at due to its spring or suspension resonance. This speed range is not important and normally speeds for wash or extraction are not selected within this range. Any wash speed in the range of 10-50 RPM and extraction speeds 150-Maximum RPM can be programmed. Further any reversing action can be programmed. Normal reversing action is 16 seconds forward, pause for 4 seconds, and 16 seconds reverse. Any temperature between 70F to 200F (20-95C) can be programmed. Any water level in the range of the machine parameters can be programmed in centimeters. The computer will automatically provide safety levels for steam injections and door operations.

Water entry into the machine is through an air gap vacuum breaker utilizing electromagnetic water valves controlled by the computer. By utilizing the air gap vacuum breaker, backflow into the water supply is impossible. The computer also controls the drain, supply dispenser, any external liquid supplies, steam injection and any other vital functions of the wash program. The computer can even record cycles and data

of importance that could be used for maintenance purpose.

The steam, if installed, is injected in the bottom of the shell via a steam injector. The steam is controlled by a steam valve that is programmed by the EL6 micro computer.

The cylinder is perforated, allowing water to pass through and drain from within during drain and extract steps. Lifting ribs inside the cylinder lift the load from the wash solution and allow the load to tumble and falling back into the solution when the load reaches the approximate 10-11 o'clock or 1-2 o'clock positions. This mechanical action removes soil from the fabric. Furthermore, the lifters are perforated on the top so that water can cascade over the goods and wet them quickly. This reduces water consumption as water is picked up at the cylinder's lowest point and lifted and splashed over the goods at the highest point as the cylinder rotates.

A stainless steel door is provided for loading and unloading. A door lock system prevents operation of the machine when the door is open. The door is locked during operation utilizing a solenoid and a manual latch for safety reasons. The door lock is provided with a magnetic sensor to indicate that the machine is locked and provide for start of the machine when the door is closed and locked.

The AC drive, contactor, circuit overload protectors, input power supply connections, external supply connections, and control transformer are behind a cover of the rear

# Installation

## Theory of Operation

of the machine.

The supply dispenser is mounted on the front of the machine and is accessed by opening the cover door. Supplies, both liquid and powder; may be added by pulling the dispenser cups out and placing the appropriate supply in each. Supplies are flushed into the machine at the proper time in the cycle, controlled by the micro computer.

Holes are provided at the rear of the machine for connection to an external, central liquid supply unit. Electrical connections are provided for the liquid supply unit on a terminal strip inside the rear control module.

# Installation

## Inspection and Uncrating

### Delivery inspection

Upon delivery, visually inspect crate, protective cover, and unit for any visible shipping damage. If the crate, protective cover, or unit are damaged or signs of possible damage are evident, have the carrier note the condition on the shipping document before the shipping receipt is signed, or advise the carrier of the conditions as soon as it is discovered.

Remove the crate and protective cover as soon after delivery as possible. If any damage is discovered upon removal of the crate and/or protective cover, advise the carrier and file a written claim immediately.

manufacturer. The serial number decal is located at the rear of the machine, inside the rear electrical enclosure, inside the loading door, and with the documentation provided with the machine. Always provide the machine's serial number and model number when ordering parts or when seeking technical assistance.

### NOTE!

Keep the manuals, installation instructions and the wiring diagrams which accompany the machine in a safe place for ready reference. They have been included with the machine at no charge. Additional copies are available at a nominal charge, or can be downloaded from our website.

### Customer Service

If literature or replacement parts are required contact the source from whom the machine was purchased or contact :

In the United States

Phone: (850)-249-2222

FAX: (850) 249-2226

e-mail: [techsupport@bandctech.com](mailto:techsupport@bandctech.com)

Web: [www.bandctech.com](http://www.bandctech.com)

In Thailand

Phone: +66 (0) 2740-5511

FAX: +66 (0) 2740-5522

e-mail: [sales@accuratethai.com](mailto:sales@accuratethai.com)

Web: [www.accuratethai.com](http://www.accuratethai.com)

for the name of the nearest authorized parts distributor.

A record of each machine is on file with the

# Installation

## SP-40 Technical Specifications

MODEL	Units		SP-40		
	Metric	US			
<b>CAPACITY:</b>					
Loading factor	1:10	kg	lbs	18.7	41
	1:12	kg	lbs	15.6	34.3
	1:13	kg	lbs	14.4	31.7
<b>OVERALL DIMENSIONS:</b>					
Width		mm	in	890	35
Depth		mm	in	1093	43
Height		mm	in	1422	56
<b>WEIGHT AND SHIPPING INFORMATION:</b>					
Net Weight		kg	lbs	591	1300
Domestic shipping weight		kg	lbs	610	1342
Domestic shipping volume		cu m	cu ft		
Export shipping weight		kg	lbs		
Export shipping volume		cu m	cu ft		
<b>CYLINDER INFORMATION:</b>					
Diameter		mm	in	680	26.8
Depth		mm	in	515	20.3
Volume		liters	cu ft	187	6.6
Perforation size		mm	in	4.8	0.188
Perforation open area		%	%	19	19
<b>CYLINDER SPEEDS (Programmable):</b>					
Wash		rpm	g	46	0.8
Distribution		rpm	g	73	2
Intermediate extraction		rpm	g	629	150
High extract 1		rpm	g	725	200
High extract 2		rpm	g	811	250
High extract 3		rpm	g	960	350

# Installation

## SP-40 Technical Specifications

MODEL	Units		SP-40	
<b>DOOR OPENING AND HEIGHT:</b>				
Diameter	mm	in	400	15.7
Height of door bottom above floor	mm	in	588	23.2
<b>DRIVE INFORMATION:</b>				
Number of motors	Number		1	
Size of motor	kW	Hp	2.2	3
<b>WATER INLETS and CONSUMPTION:</b>				
Hot water size	DN	in	20	3/4
Cold water size	DN	in	20	3/4
Additional water Inlet	DN	in	20	3/4
Average HOT water consumption/ cycle	liters	gal	193	51
Average COLD water consumption/cycle	liters	gal	102	27
<b>DRAIN OUTLETS AND CAPACITY:</b>				
Number of drains standard	Number		1	
Number of drains optional (water re-use)	Number		1	
Drain size	mm	in	76.2	3
Drain capacity	liter/min	gpm	159	42
<b>STEAM INLET and CONSUMPTION:</b>				
Steam inlet size	DN	in	13	1/2
Required steam to heat bath 10F (5.55C)LOW	kg	lbs	5.3	2.4
Required steam to heat bath 10F (5.55C)HIGH	kg	lbs	6.6	3
Average Steam consumption per cycle	kg	BHP	23	1.5

# Installation

## SP-60 Technical Specifications

MODEL	Units		SP-60		
	Metric	US			
<b>CAPACITY:</b>					
Loading factor	1:10	kg	lbs	27.4	60
	1:12	kg	lbs	22.8	50.2
	1:13	kg	lbs	21.1	46.4
<b>OVERALL DIMENSIONS:</b>					
Width		mm	in	1003	39.5
Depth		mm	in	1232	48.5
Height		mm	in	1615	63.6
<b>WEIGHT AND SHIPPING INFORMATION:</b>					
Net Weight		kg	lbs	660	1450
Domestic shipping weight		kg	lbs	705	1552
Domestic shipping volume		cu m	cu ft		
Export shipping weight		kg	lbs		
Export shipping volume		cu m	cu ft		
<b>CYLINDER INFORMATION:</b>					
Diameter		mm	in	790	31.1
Depth		mm	in	560	22
Volume		liters	cu ft	274	9.7
Perforation size		mm	in	4.8	0.188
Perforation open area		%	%	23	23
<b>CYLINDER SPEEDS (Programmable):</b>					
Wash		rpm		43	
Distribution		rpm		67	
Intermediate extraction		rpm		583	
High extract 1		rpm		673	
High extract 2		rpm		753	
High extract 3		rpm		890	
<b>CENTRIFUGAL FORCES (Programmable):</b>					
Wash		g		0.8	
Distribution		g		2	
Intermediate extraction		g		150	
High extraction 1		g		200	
High extraction 2		g		250	
High extraction 3		g		350	

# Installation

## SP-60 Technical Specifications

MODEL	Units		SP-60	
<b>DOOR OPENING AND HEIGHT:</b>				
Diameter	mm	in	450	17.7
Height of door bottom above floor	mm	in	716	28.2
<b>DRIVE INFORMATION:</b>				
Number of motors	Number		1	
Size of motor	kW	Hp	3.7	5
<b>WATER INLETS and CONSUMPTION:</b>				
Hot water size	DN	in	20	3/4
Cold water size	DN	in	20	3/4
Additional water Inlet	DN	in	20	3/4
Average HOT water consumption/ cycle	liters	gal	223	59
Average COLD water consumption/cycle	liters	gal	106	28
<b>DRAIN OUTLETS AND CAPACITY:</b>				
Number of drains standard	Number		1	
Number of drains optional (water re-use)	Number		1	
Drain size	mm	in	76.2	3
Drain capacity	liter/min	gpm	246	65
<b>STEAM INLET and CONSUMPTION:</b>				
Steam inlet size	DN	in	13	1/2
Required steam to heat bath 10F (5.55C)LOW	kg	lbs	8.4	3.8
Required steam to heat bath 10F (5.55C)HIGH	kg	lbs	9.2	4.2
Average Steam consumption per cycle	kg	BHP	35	2.2

# Installation

## SP-100 Technical Specifications

MODEL	Units		SP-100		
	Metric	US			
<b>CAPACITY:</b>					
Loading factor	1:10	kg	lbs	47.8	105
	1:12	kg	lbs	39.8	87.6
	1:13	kg	lbs	36.8	81
<b>OVERALL DIMENSIONS:</b>					
Width		mm	in	1194	47
Depth		mm	in	1372	54
Height		mm	in	1778	70
<b>WEIGHT AND SHIPPING INFORMATION:</b>					
Net Weight		kg	lbs	1081	2380
Domestic shipping weight		kg	lbs	1098	2416
Domestic shipping volume		cu m	cu ft		
Export shipping weight		kg	lbs		
Export shipping volume		cu m	cu ft		
<b>CYLINDER INFORMATION:</b>					
Diameter		mm	in	940	37
Depth		mm	in	690	27.2
Volume		liters	cu ft	478	16.9
Perforation size		mm	in	4.8	0.188
Perforation open area		%	%	24	24
<b>CYLINDER SPEEDS (Programmable):</b>					
Wash		rpm		39.5	
Distribution		rpm		62	
Intermediate extraction		rpm		540	
High extract 1		rpm		624	
High extract 2		rpm		698	
High extract 3		rpm		825	
<b>CENTRIFUGAL FORCES (Programmable):</b>					
Wash		g		0.8	
Distribution		g		2	
Intermediate extraction		g		150	
High extraction 1		g		200	
High extraction 2		g		250	

# Installation

## SP-100 Technical Specifications

MODEL	Units		SP-100	
<b>DOOR OPENING AND HEIGHT:</b>				
Diameter	mm	in	483	19
Height of door bottom above floor	mm	in	795	31.3
<b>DRIVE INFORMATION:</b>				
Number of motors	Number		1	
Size of motor	kW	Hp	5.5	7.5
<b>WATER INLETS and CONSUMPTION:</b>				
Hot water size	DN	in	20	3/4
Cold water size	DN	in	20	3/4
Additional water Inlet	DN	in	20	3/4
Average HOT water consumption/ cycle	liters	gal	371	98
Average COLD water consumption/cycle	liters	gal	174	46
<b>DRAIN OUTLETS AND CAPACITY:</b>				
Number of drains standard	Number		1	
Number of drains optional (water re-use)	Number		1	
Drain size	mm	in	76.2	3
Drain capacity	liter/min	gpm	473	125
<b>STEAM INLET and CONSUMPTION:</b>				
Steam inlet size	DN	in	13	1/2
Required steam to heat bath 10F (5.55C)LOW	kg	lbs	14	6.4
Required steam to heat bath 10F (5.55C)HIGH	kg	lbs	16	7.3
Average Steam consumption per cycle	kg	BHP	60	3.6

# Installation

## Dimensional Clearances

When installing the washer-extractor, it is important to allow adequate clearance on all sides of the machine. When multiple machines are installed, it is important to allow for the specified minimum clearances between machines. The following table shows recommended minimum clearances for the various freestanding models.

### Note

The dimensions are approximate and subject to normal manufacturing tolerances. If exact dimensions are required for construction purposes, request certified drawings from the factory. We reserve the right to make changes at any time without notice.

	UNITS Metric	UNITS US	SP Series			
			Recommended		Minimum	
(A) Minimum rear clearance	mm	in	760	30	305	12
(B) Minimum clearance between machine and wall	mm	in	455	18	25	1
(C) Minimum clearance between machines	mm	in	455	18	25	1
(D) Minimum front clearance	mm	in	838	33	838	33

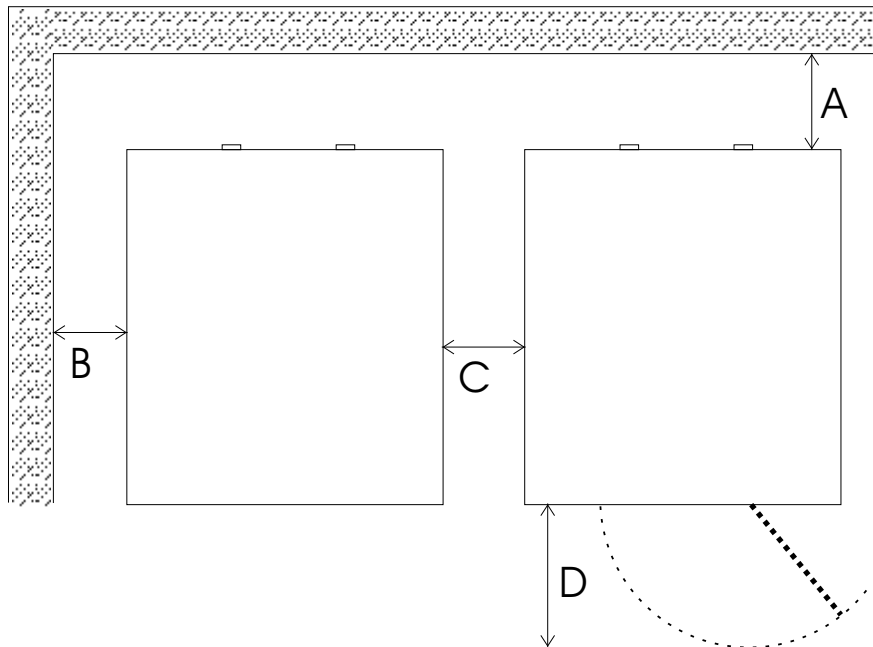

# Installation

## Machine Foundation

Thoroughness of details must be stressed with all foundation work to insure a stable unit installation, eliminating possibilities of excessive vibrations during extraction.

For a successful installation, a smooth level surface, so that the entire base of the machine is supported and rests on the mounting surface, is absolutely required. Note: Do not support the machine on only four points.

Note: Freestanding washer-extractors do not require anchoring bolts unless specified by state or local codes. However it is always recommended that the machines be anchored.

Special care must be taken when machines are installed on an upper floor. Make sure that the floors are designed to carry the static and dynamic loads of the machines. Further vibrations should be taken into consideration so that the machine does not create vibrations in the building. Static and dynamic loads on the floor or foundation are shown in the table below. This table can be used as reference when

designing floors and foundations. See figure (next page) for mounting bolt layout measurement and pattern.

Ensure that the machine is installed on a level floor of sufficient strength and that the recommended clearances for inspection and maintenance are provided. Never allow the inspection and maintenance space to be blocked



## Floor Load Data

	Static floor load		Static pressure		Dynamic floor load		Max dynamic load		Dynamic pressure		Dynamic Frequency
	kN	lbs	kN/m2	lbs-ft2	kN	lbs	kN	lbs	kN/m2	lbs-ft2	Hz
SP-40	5.7	1300	6.34	134.4	0.934	210	0.934	210	1.04	21.7	16
SP-60	7	1584	6.35	133.5	1.4	315	1.4	315	1.27	26.5	14.83
SP-100	9.3	2100	5.9	123.7	2.3	525	2.3	525	1.46	30.9	13.75

# Installation

## Mounting Bolt Installation

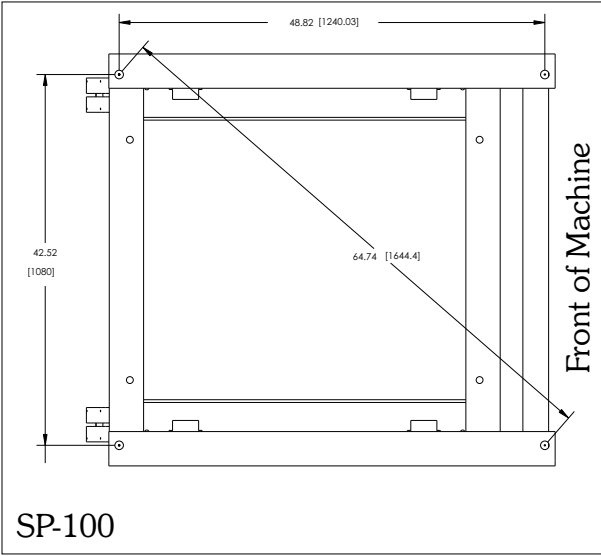
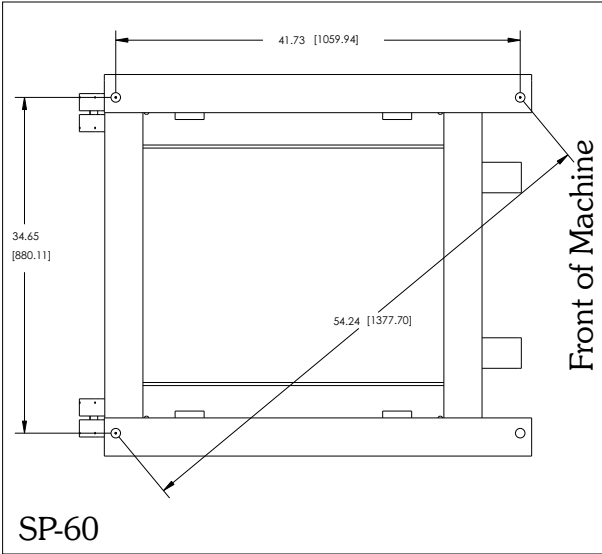
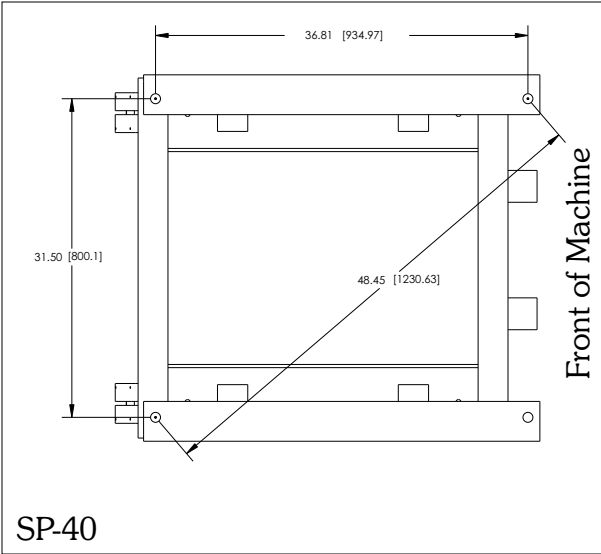

**Mounting Bolt Installation**  
 All SP Machines use 1/2-13 bolts. Embed the bolts in 3500 psi reinforced concrete with a minimum of 4" thickness. The threaded end of the bolt should extend 2 inches from the surface of the floor. Grouting is recommended, but not required.

# Installation

## Mounting Bolt Installation

All B&C washer-extractors should be secured by the use of machinery anchor bolts. High strength machinery anchors should be embedded in 3500 psi (24000 N/m<sup>2</sup>) reinforced concrete. See Figure. For detailed information regarding the machine anchor bolt, see the instructions included with the anchor bolts themselves. The following information is just an example.

After the concrete has cured, proceed as follows:



Select a carbide drill bit with a diameter equal to the anchor diameter. Drill hole to any depth exceeding the desired embedment.



Clean hole or continue drilling to accommodate drill fines (concrete dust). Please wear eye protection.

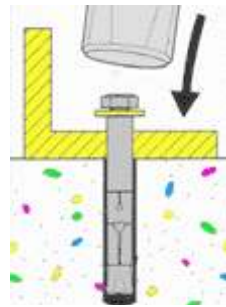

Drive the anchor into the hole through material being fastened until washer is flush with material.

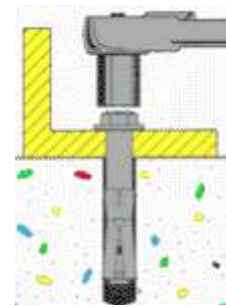

Expand bolt by tightening the anchor 3 to 5 turns, or to the specified torque requirements.

Place the machine adjacent to the foundation. Do not attempt to move it by pushing on the sides.

1. Remove the wood skid by unscrewing the carriage bolts holding it to the bottom frame of the machine.
2. Carefully place the machine over the anchor bolts. Raise and level it 1/2 inch above the floor on four points, using spacers that can be removed.
3. Fill the spaces between the machine base and floor with machinery grout. Grout completely under all frame members. Remove front panel and rear panel to gain access to all frame members. Force grout under the machine base until all voids are filled.
4. Remove the spacers carefully, allowing the machine to settle into the wet grout.
5. Attached the mounting bolt washers and lock nuts to the anchor bolts after the grout has hardened. Tighten the lock nuts by even increments-one after the other-until all are tightened evenly and the machine is fastened securely to the floor. The nuts should be tightened in a diagonal fashion, which will help ensure equal tension at all anchor points.
6. Remove the transportation brackets which secure the moving components of the machine during shipping.

# Installation

## Transportation Brackets

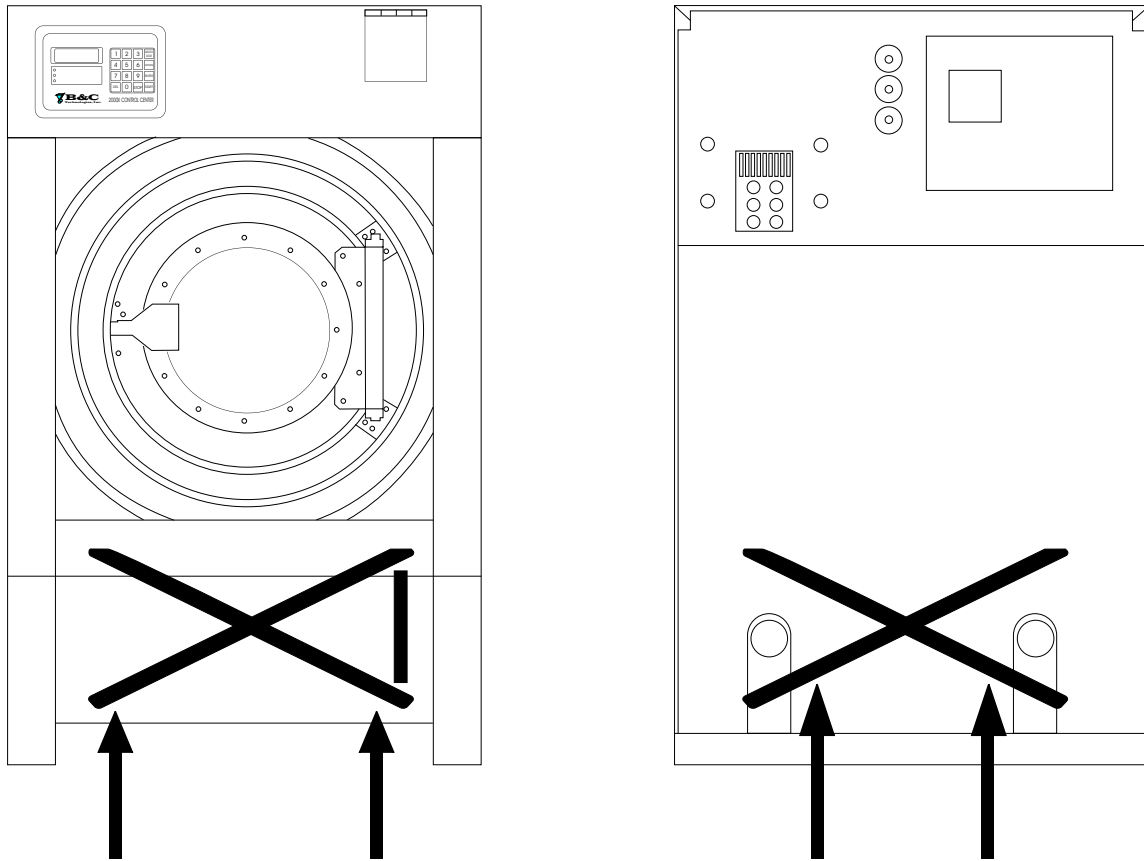

Location of transportation brackets inside the machine

Remove both front and rear transportation brackets, as well as the bracket located on the lower inside right of the machine. Failure to remove shipping brackets before operation of the SP series will void your warranty.

# Installation

## Drain Connection

A drain system of adequate capacity is essential to the machine performance. Ideally the water should empty through a 4 inch vented pipe directly into a sump or floor drain. See figure.

A flexible connection must be made to a vented drain system to prevent an airlock or siphon effect. If proper drain size is not available or practical, a surge tank is required. A surge tank in conjunction with a sump pump should be used when gravity drainage is not possible, such as in below-ground-level installations.

installation procedures is attempted, the customer or installer should contact the manufacturer. Increasing the drain hose length, installing elbows, or causing bends will decrease drain flow rate and increase drain time, impairing machine performance. If the drain arrangement is inadequate, the machine will not extract and will not discharge water properly.

See table below for specific drain information.

Before any deviation from specified

## Drain Sizing

	Units		BMC SP Series					
	Metric	US	SP-40		SP-60		SP-100	
Drain connection Size	mm	in	76	3	76	3	76	3
Drain flow capacity	liters/min	gpm	310	80	581	150	581	150
Minimum drain pit size	liters	gal	213	55	388	100	388	100

## Drain Construction

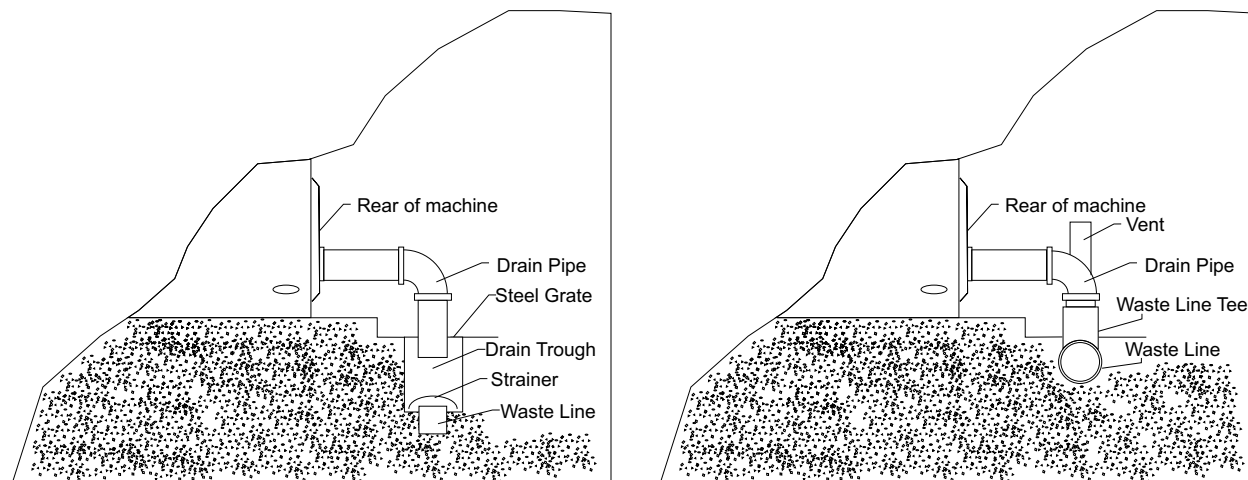

# Installation

## Electrical Installation

The AC drive requires a clean power supply free from voltage spikes and surges. A voltage monitor should be used to check incoming power. The customer's local power company may provide such a monitor.

The AC drive provides for an internal circuit breaker. A separate circuit breaker governs the control circuit.

If input voltage measures above 240V for a 200 V drive or above 460V for a 400V drive, either ask the power company if their representative can lower the voltage or install a step-down transformer kit available from the manufacturer. Voltages above 250V and 490V require additional measures. Contact the distributor or the manufacturer for assistance.



This machine must be installed, adjusted, and serviced by a qualified electrical maintenance personnel familiar with the construction and operation of this type of machinery. They must also be familiar with the potential hazards involved. If this warning is not observed, personal injury or equipment damage resulting in voiding the warranty may result.



When controlling the AC drive with a parameter unit, the machine's computer and its safety features are bypassed. This would allow the basket to rotate at high speeds with the door open. When using a parameter unit to control the AC drive, a large sign should be placed on the front of the machine warning people of the imminent danger.



Never touch terminals or components of the AC drive unless power is disconnected and the "CHARGE" indicator LED is off. The AC drive retains potential deadly voltage for some time after the power is disconnected. There are no user-serviceable parts inside the AC drive. Tampering with the drive will void the warranty.



Dangerous voltage are present in the electrical control boxes and at the motor terminals. Only qualified personnel familiar with electrical test procedures, test equipment, and safety precautions should attempt adjustments and troubleshooting. Disconnect power from the machine before removing the control box cover, and before attempting any service procedures.

# Installation

## Electrical Installation

	200-240V, 50-60Hz, 3PH			380-480V, 50-60Hz, 3PH		
Machine	Max Amps	Breaker	Wire Size	Max Amps	Breaker	Wire Size
SP-40	5	15	14ga / 2.5mm	3	15	14ga / 2.5mm
SP-60	8	15	14ga / 2.5mm	4	15	14ga / 2.5mm
SP-100	18	20	10ga / 4mm	9	15	14ga / 2.5mm

	200-240V, 50-60Hz, 1PH		
Machine	Max Amps	Breaker	Wire Size
SP-40	8	15	14ga / 2.5mm
SP-60	14	15	14ga / 2.5mm
SP-100	31	40	10ga / 4mm

Note: For single phase (1 $\phi$ ) operation, connect input power to L1 and L2, leaving the L3 terminal open.

Note: Do not use phase adders (roto-phase) on inverter driven equipment!

Note: Wire sizes shown are for copper, THHN, 90 conductor per NEC article 310 (USA).

The machine should be connected to an individual branch circuit not shared with lighting or other equipment.

Because this is a vibrating machine, the use of SO cable or similar, with a twist-lock plug, to connect the machine to main power is recommended. A shielded liquid tight or approved flexible conduit with proper conductor of correct size installed in accordance with National Electric Code (USA) or other applicable codes is also acceptable. The connection must be made by a qualified electrician using the wiring diagram provided with the machine. See the Electrical Connection data Chart for correct wire sizes.

Use wire sizes indicated in the chart for runs up to 50 feet (15m). Use next larger size for runs of 50 to 100 feet (15-30m). Use 2 sizes larger for runs greater than 100 feet (30m).

For personal safety and for proper operation, the machine must be grounded in accordance with state and local codes and in the USA in accordance with the National Electric Code, article 250-96. The ground connection must be to a proven earth ground, not to conduit or water pipes.

Do not connect the ground to the neutral (N) leg at the terminal strip (if so equipped).

If a DELTA supply system is used, the high leg should be connected to L3, since control voltage is derived from L1 and L2.

Insure that the control transformer taps are connected in accordance with the incoming line voltage. Verify connections as shown on the schematic with each machine.

# Installation

## Water Connection

Individual hot and cold plumbing lines with individual shut-off valves must be available to the machine. Hot water should be minimum of 160F (70C). If lower temperature water is used the machine should be equipped for steam heating to heat the wash solution to desired temperature. Best performance will be realized if water is provided at a pressure of 30-85 psi (2-7 Bar). Although the machine will function properly at lower pressures, increased fill times will occur. If the fill time exceeds 5 minutes, the EL6 control will display a WDT (watch dog timer) alarm, indicating that the machine did not fill quickly enough. See the EL6 programming manual for further details.

Flush the water system for at least two minutes prior to initial use..

Use flexible hoses and install separate screen filters in the lines to keep rust and other foreign particles out of the solenoid valves. Hang the hoses in a large loop. Do not allow the hoses to kink. The water connections to the machine should be supplied by a hot and cold water line of least the sizes shown in the table below. Installation of additional machines will require proportional larger water lines, see table.

To avoid eventual water hammer in the water line, suitable devices to reduce the water hammer should be installed.

NUMBER OF MACHINES	Pipe Size	
	SP Series	
	DN	Inch
1	25	1
2	25	1
3	40	1-1/2
4	40	1-1/2
5	50	2
6	50	2

# Installation

## Steam Connection



Never touch internal or external steam pipes, connections, or components. These surfaces can be extremely hot and will cause severe burns. The steam must be turned off and the pipe, connections, and components allowed to cool before the pipe can be touched

For machines equipped with optional steam heat, install piping in accordance with approved commercial steam practices.

Steam requirements are shown in the table below. Failure to install the supplied steam filter may void the warranty.

STEAM INLET and CONSUMPTION:	UNITS		SP-40	
Steam inlet size	DN	in	13	1/2
Required steam to heat bath 10F (5.55C)LOW	kg	lbs	1.2	2.4
Required steam to heat bath 10F (5.55C)HIGH	kg	lbs	1.4	3.1
Average Steam consumption per cycle	kg	lbs	23	50.6

STEAM INLET and CONSUMPTION:	UNITS		SP-60	
Steam inlet size	DN	in	13	1/2
Required steam to heat bath 10F (5.55C)LOW	kg	lbs	1.5	3.2
Required steam to heat bath 10F (5.55C)HIGH	kg	lbs	1.8	4
Average Steam consumption per cycle	kg	lbs	31	66

STEAM INLET and CONSUMPTION:	UNITS		SP-100	
Steam inlet size	DN	in	20	3/4
Required steam to heat bath 10F (5.55C)LOW	kg	lbs	2.5	5.5
Required steam to heat bath 10F (5.55C)HIGH	kg	lbs	3.4	7.4
Average Steam consumption per cycle	kg	lbs	60	132

# Installation

## External Chemical Supplies



Wear Eye and hand protection when handling chemicals. Always avoid direct contact with raw chemicals. Read the manufacturer's directions for accidental contact before handling chemicals. Ensure that an eye-rinse facility and an emergency shower are within easy reach. Check at regular intervals for chemical leaks.

The following procedures must be observed when connecting any chemical injector to the washer-extractor. See the figure for a typical supply injection system setup. Undiluted chemicals dripping can damage the machine. Therefore, all chemicals supply dispenser pumps should be mounted below the washer's injection point. All dispenser tubing should also run

below the injection point. Loops do not prevent drips if these instructions are not followed. Failure to follow these instructions could damage the machine and void the warranty.

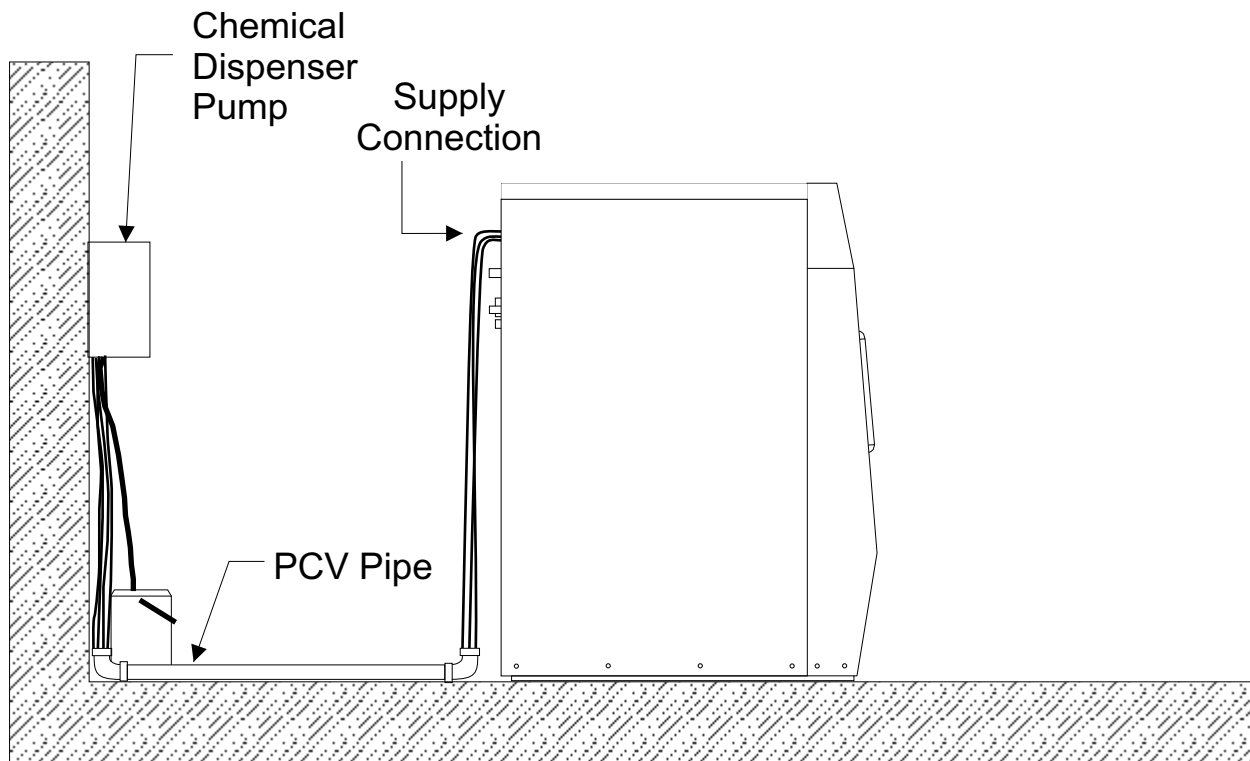

# Installation

## External Chemical Supplies

The supply compartment on the B&C SP models is located on the front of the machine. Supply cups can be accessed by opening the dispenser lid. The supply cups can be removed and filled as desired. Supply compartments are numbered 1,2,3,4 and 5 from the left of the machine to the right for the optional 5 cup system..

External supply connections for the B&C SP washer-extractors are located on rear of the machine at the vacuum breaker. Hose connections should be made via the threaded connectors. See figure.

1. Remove plugs from base. See figure.
2. Install the supplied chemical nipple, using teflon tape.
3. Insert tubes onto the nipples, using small hose clamps or wire ties to prevent the hose from slipping off.

The chemical flush water valve (relay 12) should be used with each chemical signal (see the EL6 programming manual for details).

For the plastic supply box, you must drill the nipples prior to use (max 1/4" bit). A 1/2 NPT connection is also provided for flushing systems. The chemical flush valve is not necessary.

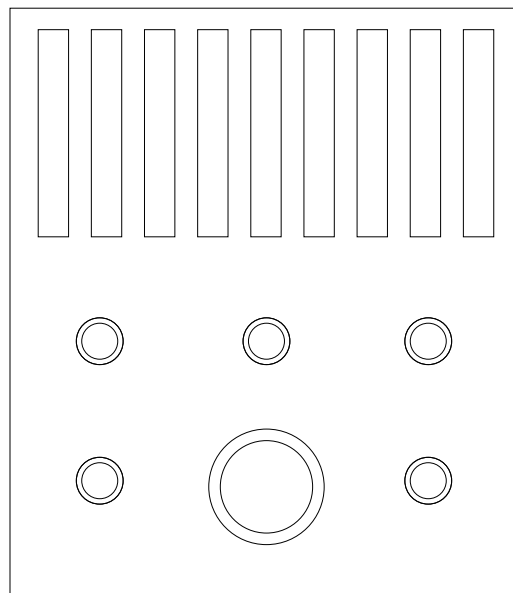
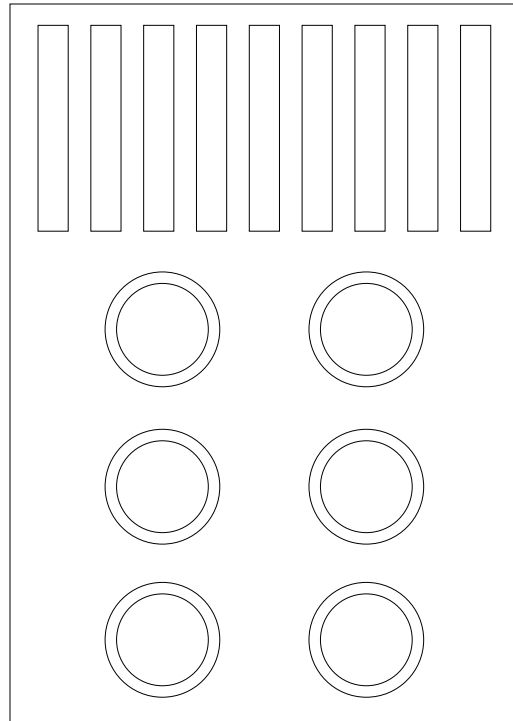

# Installation

## Electrical Connections

Connection terminals are located in the rear control box for output signals to the chemicals injection supply pump.

Do not attempt to increase fuse rating as this cause damage to the washer-extractor circuitry.

Terminals SUPPLY 1 through SUPPLY 8 provide signals for external chemical supply pumps. The signal is a maximum of 1 amp at 24V 50/60Hz.

Any injection system pump, which requires 24-220V AC must be powered by a separate external power source.



Attempting to obtain power from the machine terminals may damage the machine circuit and/or the chemical injection system. Consult the chemical injection supply system instructions for operational details.

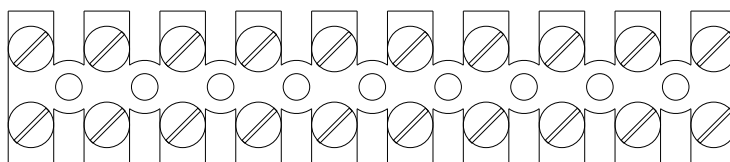

1 2 3 4 5 6 7 8 COM

**CHEMICAL INJECTION SIGNALS**

**24VAC, 1.0A MAX TOTAL LOAD**

# Installation

## Control Function Test

The machine should be cleaned after the installation is complete. A function test should then be executed on the unloaded machine as follows:

1. Check the proper supply for such characteristics as correct voltage, phase, and cycles to be certain they are correct for the machine.
2. Open manual shut-off water valves to the machine.
3. Press Emergency Stop button.
4. Apply power to the machine.
5. Release the Emergency button.
6. Check the door interlock before starting the machine.
  - a. Attempt to start the machine with the door open. The machine should not start with the door open.
  - b. Close the door without locking it and attempt to start the machine. The washer should not start with the

door unlocked.

- c. Close and lock the door and start a cycle. Attempt to open the door while the cycle is in progress. The door should not open.

If the door lock and interlock are not functioning properly, call a service technician.

7. For testing, select program 30 by pressing key 3 and key 0 on the keypad. Then press enter and the Start key. Run the complete program, checking operation of water inlet valves, drain, and extract functions. Program 30 is a test program that goes through most machine functions.
8. Cylinder rotation must be counter-clockwise in the extract step. If rotation is not correct, disconnect the power to the machine. A qualified technician must reverse any two leads between the AC drive and the motor. See figure.

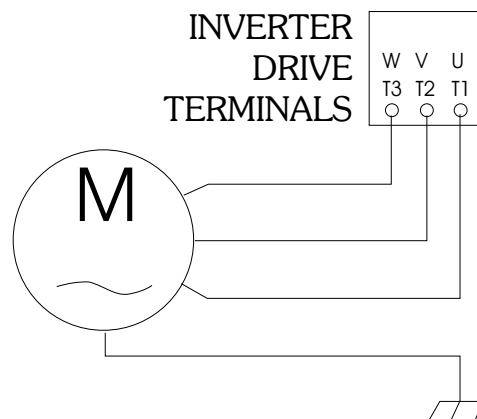

# Operation

## Door Lock Operation

The lock system uses a "push-to-open / push-to-close" style mechanism which differentiates it from any other door lock in the industry. This design was developed as a result of analyzing the shortcomings of other door lock mechanisms on the market. It hence has many fundamental safety & mechanical advantages.

### Operation

#### Opening & Closing

To open the door the machine must not be running a wash program -- "Program n." should be displayed on the EL6. Simply push and release the door handle with the palm of your hand. As you push the handle in the door lock solenoid will energize and the pin will retract and release the door. Then as you release the pressure on the handle the door will be free and you can pull it open. To close the door swing it closed, then push the handle firmly until you hear the solenoid engage, releasing the door lock pin to lock the door. When you start a wash program the door lock is securely disabled so that the door cannot be accidentally opened.

#### Periodic Maintenance

- ▶The door should be tested every day for safe operation by trying to start a program with the door open. If the machine will begin operation in this state it should immediately be removed from service, locked out, and a qualified service technician called to repair it.
- ▶If the door lock is malfunctioning in any way, the machine should immediately be removed from service, locked out, and a qualified service technician called to repair it.
- ▶The door lock pin and handle hinge should be lubricated with "silicon spray lube" monthly. This product is available at almost any auto parts store. This procedure does not require any disassembly.
- ▶The door handle nose bushing should be checked for wear and cracking monthly. It should be replaced when it is cracked, missing, or worn out.
- ▶The door lock tongue and lock pin alignment should be checked monthly and adjusted as needed.
- ▶For detailed instructions on door alignment, request TSB009 when contacting technical service.

# Operation

## Machine Loading

Proper loading of your SP series washer-extractor is a great factor in determining both the performance and longevity of your investment. Small loads are wasteful on many levels:

1. Small loads waste water, chemicals, electricity, and most expensively, time. Running your machine at lower than its rated capacity costs you time and money.
2. Small loads cause more wear and tear on the machine. Small loads are very difficult to balance properly, and will cause excessive vibration during extract. These vibrations mean that bearing loads are higher, reducing the life of the main bearings. The extra vibrations also tend to cause other fasteners on the machine to loosen over time, causing premature wearing and more frequent service.

3. Smaller loads are not easier for the machine to handle - quite the opposite, they are more difficult on the entire machine. When the machine is under loaded, it causes greater stress on the inverter drive, belts, and motor, leading to reduced life of these expensive components.

Refer to the chart below for proper loading.

### Dry Weight Capacity

Model	Capacity	
SP-40	40 lbs	18 kg
SP-60	60 lbs	27 kg
SP-100	100 lbs	45 kg

If a scale isn't available, fill the machine up with goods to be laundered. Do not attempt to "stuff" the machine full, but ensure that there is no gap at the top of the cylinder.

# Operation

## Wash Program Execution

After power is applied to the machine, and the internal diagnostics are complete, the machine is ready for a program to be chosen. The display will show:

PROGRAM N. \_

Using the keypad, type the number of the program you wish to run followed by the ENTER key. Standard programs are outlined in the EL6 stock program list, included with the machine. The display will change to show the first cycle of the selected program:

PRWH 1 EXECUT.?

Press START to execute the program, or RESET to return to program selection. While the program is executing, the display shows the current segment of the program, and the ending condition of the segment. See the following examples:

### Level

If the end requirement of the segment (step) is a particular water level, the display will show:

RINSE1 LVL=cm12

cm12 is the actual water level in the machine (12 centimeters). Pressing the LEVEL key shows, for 3 seconds, the required value to advance. If INC or DEC is pressed, you can temporarily modify the value for the current step. Pressing TEMP allows you to see the current temperature of the water. Pressing the TIME key shows the watch dog timer (WDT) value for the current step.

### Temperature

If the end condition of the segment is a temperature, the display will show:

WASH3 TEMP = 35C

where 35C is the actual temperature of the wash solution. By pressing TEMP the display will change, for 3 seconds, show the required step temperature for advance. Pressing INC or DEC allows modification of the value for the step. Pressing LEVEL allows you to see the current water level. Pressing the TIME key shows the watch dog timer (WDT) value for the current step.

### Time

If the end of the step calls for a time to elapse, the display shows:

RINSE1 T = 2m 30s

In this case, the display shows the time left in the step. INC and DEC allow you to add or subtract minutes for the current cycle. TEMP allows you to view the current water temperature, and LEVEL shows the current water level.

Note: During heating, fill and drain phases, the WDT (watch dog timer) is activated. If the phase does not complete before the timer expires, an alarm will be displayed indicating that the particular phase did not complete within the time allowed.

### Single Step Execution

A single step or cycle of a wash program can be executed. At the main prompt, enter zero for the program number. For two seconds, the display changes to:

# Operation

## Wash Program Execution

SINGLE CYCLE

Then, using the INC and DEC keys, you may choose the cycle you wish to run (PREWASH, WASH, RINSE, SPIN, UNROLL). When you have selected your cycle, confirm by pressing ENTER. The display changes to:

RUN?

Pressing the START key will start the machine.

### *Partial Program*

A program can be partially run. After selecting the program you wish to execute, the display will show:

RUN?

Instead of pressing ENTER to execute the program, press the ADVAN key. The cycles within the program will be displayed incrementally. Choose the point at which you would like to begin, and press the START key. The machine will begin operation from this point.

### *Displaying the Current Program and Step*

While the machine is in operation, pressing then ENTER key will cause the display to show the current program number and step.

PRG 1 STP 3

### *Soak*

You can insert a pause at any point of the wash program with the exception of distribution and spin. To do so, simply press

the PAUSE key. The display will begin showing a time, counting up as long as the machine remains paused. Pressing the START key will restart the program at the point it was paused. As long as the machine is paused, all other WDT (watch dog timers) are paused as well.

### *Advance*

While any program is running, you can end the current step and advance to the next one by pressing the ADVAN key. If the key is pressed during a spin, the spin will be aborted, and the standard spin slow down time will be activated.

### *Halting a Program*

At any time during the execution of the wash program, the running program can be terminated by pressing the STOP key.

### *Water Level Refresh*

While a program is running, if the water level drops to a level which is 3cm below the target level, cold water will automatically be added to replenish the level.

### *Unbalance*

If, during a spin segment, the load is excessively out of balance, the spin will stop, and a redistribution of the goods will take place. If three consecutive out of balances occur, the machine will end the program. After the first unbalance, the balance indicator will light on the control panel.

# Operation

## Wash Program Execution

### *Power Failure*

If the power fails during execution of a program, and is of less than one second, it is ignored. If the failure is longer than one second, the machine stops. Upon restoration of mains power, the display shows CYCLE CONTINUE? and the power failure indicator illuminates on the front panel. If you wish to restart the program at the point in which power failed, press the START key. At this point, the program restarts at the point of power failure and the power failure indicator turns off. If you wish to cancel the program, simply press the RESET key. This function is not active while a single cycle is running.

### *End of Program*

When a program has completed, the message PLEASE WAIT is displayed and the buzzer sounds. The buzzer can be silenced by pressing the RESET key. If the temperature or water level are out of bounds, the display shows the offending value and the door cannot be opened.

### *Malfunction Alarms*

The state of the water temperature and water levels are constantly monitored to prevent functioning problems with these devices. Watch Dog Timers (WDT) are used to prevent cycle failure when temperatures, fills, drains, and levels don't meet programmed values. In the event of a program fault, the buzzer sounds and the display changes to show the fault:

#### LEVEL FAULT

Indicates a problem with the level sensing system. This could be a loose or cracked water level tube, the level sensor, or the level sensing circuit. As long as the system detects a problem with the level sensing system, the machine will be inoperable. The buzzer can be disabled with the RESET

#### TEMP FAULT

Indicates a problem with the temperature sensing circuitry, temperature probe, or wiring. The machine continues to function, although auxiliary heating (if equipped) is disabled. The Temperature fault indicator on the control panel will be illuminated.

#### WDT TEMP EXPIRED

Indicates the programmed temperature was not reached within the allotted time. The most common cause is a malfunctioning auxiliary heating system. A short WDT time and very cold water can also cause this problem. Pressing the START key will cancel the alarm.

#### WDT LEVEL EXPIRED

Indicates the programmed level was not reached within the allotted time. The most common causes:

During Fill

- ▶ Faulty water inlet valve
- ▶ Low or no water pressure
- ▶ Faulty drain valve
- ▶ Problem with water level tube

Pressing START will continue the program,

# Operation

## Wash Program Execution

while RESET will cancel the program.

During Drain

- ▶ Drain valve blocked
- ▶ Drain hose blocked
- ▶ Faulty Drain Valve

Press RESET to end the program.

OVERLOADED!

Indicates a fault in the drive system. On inverter driven equipment, indicates a drive fault, on non inverter driven equipment, indicates a motor overload condition. Press RESET to clear the fault. If this fault recurs during the next wash program, contact a qualified service technician.

DOOR OPEN!

Indicates the door is not closed properly. This fault disables the machine until cleared, and aborts a program if active. Press RESET to clear the fault.

DRAIN

Indicates a water level of greater than 2cm at the onset of spin. The machine will resume the spin when the level falls below the threshold. Press RESET to abort the cycle.

For further information regarding access functions and programming, see the EL-6 Computer Programming and Operating Instructions manual, included with the machine.

# Maintenance

## Routine Maintenance

Routine maintenance maximizes operating efficiency and minimizes downtime. The maintenance procedures described below will prolong the life of the machine and help prevent accidents.

Daily, weekly, monthly, and quarterly checklists are provided at the end of this section. Laminate the checklists to preserve them for repeated copying. Operators and technicians are encouraged to add checks specific to their machine's particular application. When possible, space is provided on the checklists for this purpose.

The following maintenance procedures must be performed regularly at the required intervals.



Install all panels that are removed to perform service and maintenance procedures. Do not operate the machine with missing guards or with broken or missing parts. Do not bypass any safety

devices!

### Daily

1. Inspect water inlet valve hose connections on the back of the machine for leaks.
2. Inspect steam hose connections for leaks, where applicable.
3. Verify that insulation is intact on all external wires and that all connections are secured. If bare wire is evident, call a service

technician.

4. Check door interlock before starting operation:

- a. Attempt to start the washer with the door open. The washer should not start with the door open.
- b. Close the door without locking it and attempt to start the machine. The machine should not start with the door open.
- c. Close and lock the door and start a cycle. Attempt to open the door while the cycle is in progress. The door should not open. If manual latch is moved out of position the machine should stop.

If the door lock and interlock are not functioning properly, call a service technician.

### End of the day

1. Clean the door gasket of residual detergent and foreign matters.
2. Clean the automatic supply dispenser and the lid inside and out with mild detergent. Rinse with clean water.
3. Clean the washer's top, front and side panels with mild detergent. Rinse with clean water.
4. Leave loading door open at the end of each day to allow moisture to evaporate.

# Maintenance

## Routine Maintenance

NOTE: Leave loading door open at end of each complete cycle to allow moisture to evaporate. Unload the machine promptly after each completed cycle to prevent moisture build up.

### Weekly

1. Check the machine for leaks.
  - a. Start an unloaded cycle to fill the machine.
  - b. Verify that door and door gasket do not leak.
  - c. Verify that the drain valve is operating. If water does not leak out during the prewash segment, drain valve is closed and functioning properly.
2. Clean the AC drive box air filters.
  - a. Snap off the external plastic cover which contains the filter. Remove the foam filter from the cover.
  - b. Wash the filter in a mild soap solution or vacuum it clean.

### Monthly

NOTE: Disconnect power to the machine at its source before performing the monthly maintenance procedures.

1. Each month or after every 200 hours of operation, lubricate bearing and seals. See instructions on the machine.
  - a. Use a premium grade lithium based

#2 grease. Never mix two types of grease, such as petroleum and silicone.

- b. Pump the grease gun slowly, permitting only the following number of strokes:
  1. Bearing grease fitting, 2 strokes
  2. Seal grease fitting, 1 stroke.

Do not pump the grease gun if grease comes out of the bearing housing. This can result in over lubrication, causing damage to bearings and seals.

2. If the machine is provided with automatic lubricators, check that they are injecting grease. Normally they last for approximately one year. Mark new lubricators with installation date

3. Clean the AC drive fins:
  - a. Remove the AC drive box cover.
  - b. Blow the fins clean using compressed air at a pressure of 60-90 psi ( 4-6 Bar) or by using canned compressed air. Use care to avoid damaging cooling fan or other components.

NOTE: No amount of visible foreign matter should be allowed to accumulate on fins or the finger guard.

4. Use the following procedures to determine if V-belts require replacement or adjustment. Call a qualified service technician in either case.

- a. Check V-belts for uneven wear and frayed edges.

# Maintenance

## Routine Maintenance

- b. After disconnecting power to the machine and removing all panels necessary for access to the drive belts, use the following method to verify that the V-belts are properly tensioned. Belt tensioning is straightforward, and accomplished by loosening the tension adjusting bolts and adjusting the belts to the proper tension. Then the bolts should be tightened. See figure.
- c. Verify that V-belts are properly aligned by checking pulley alignment. Place a straightedge across both pulley faces. The straight edge should make contact with the pulleys in four places. See figure.

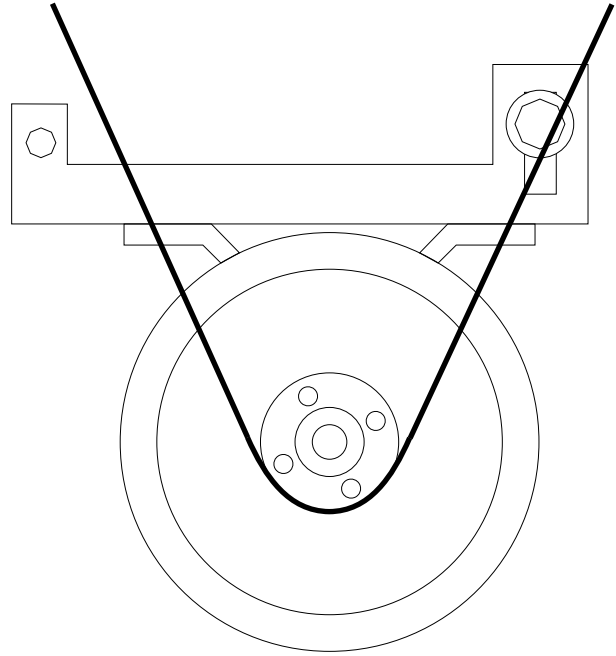

BELT TENSION CHART				
Machine Model	Deflection		Force Applied	
	Inch	mm	Lbs	kg.
SP-40				
SP-60	5/16"	8	4.4	2
SP-100				

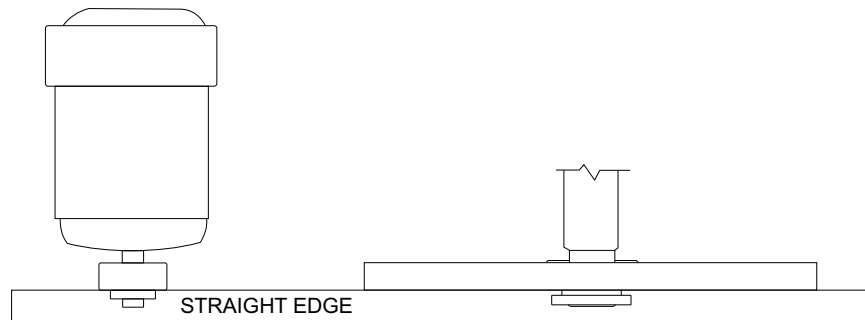

# Maintenance

## Routine Maintenance

5. Remove back panel and check overflow hose and drain hose for leaks.

6. Remove top cover and check the supply dispenser hoses and hose connections.

7. Clean inlet hose filter screen:

- a. Turn water off and allow valve to cool, if necessary.
- b. Unscrew inlet hose and remove filter screen.
- c. Clean with compressed air and reinstall. Replace if worn or damaged.

8. Tighten motor mounting bolts and bearing housing bolts, if necessary.

9. Use compressed air to clean lint from motor.

10. Clean external water and steam filters.

## Quarterly

NOTE: Disconnect power to the machine before performing the quarterly maintenance procedures.

1. Tighten door hinges and fasteners, if necessary.

2. Tighten anchor bolts, if necessary.

3. Check all painted surfaces for bare metal (matching paint is available from the manufacturer.)

a. If bare metal is showing, paint with primer or solvent-based paint.

b. If rust appears, remove it with sand paper or chemical means. Then paint with primer or solvent-based paint.

4. Clean steam filter, where applicable. See diagram below.

1. Turn off steam supply and allow time for the valve to cool if necessary.

2. Unscrew nut.

3. Remove element and clean.

4. Replace element and nut.

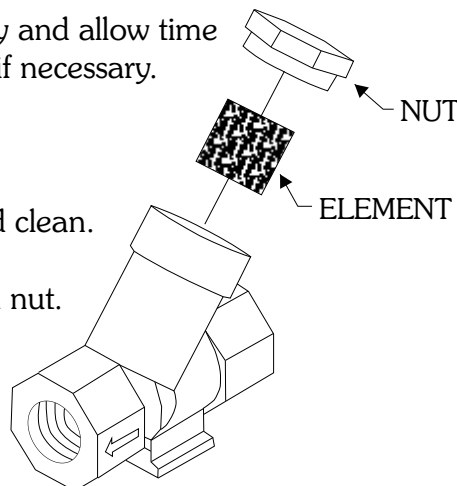

# Maintenance

## Routine Maintenance

### Care of stainless steel

Maintain the natural beauty of stainless steel and prolong its service life by following these steps.

1. Ordinary deposits of dirt and grease can be removed with detergent and water. The metal should be thoroughly rinsed and dried after washing. Periodic cleaning will help to maintain the bright surface appearance and prevent corrosion.

2. Contact with dissimilar metal should be avoided whenever possible. This will help prevent galvanic corrosion when salty or acidic solutions are present.

3. Salty or acidic solutions should not be allowed to evaporate and dry on stainless steel. They may cause corrosion. Ensure that the stainless steel is wiped clean of acidic solution residues.

4. Deposits that adhere to the stainless steel should be removed, especially from crevices and corners. When using abrasive cleaners, always rub in the direction of the polish lines or grain of the stainless steel to avoid scratch marks. Never use ordinary steel wool or steel brushes on the stainless steel. Use stainless steel wool or soft non-metal bristle brushes..

5. If the stainless steel appears to be rusting the source of the rust may actually be an iron or steel part not made of stainless steel, such as a nail or screw. One remedy is to paint all carbon steel parts with a heavy protective coating. Stainless steel fasteners should be used

when possible.

6. Discolorations or heat tint from overheating may be removed by scouring with powder or by employing special chemical solutions.

7. Sanitizers or sterilizing solutions should not be left in stainless steel equipment for prolonged periods of time. They often contain chlorine, which may cause corrosion. The stainless steel should be cleaned and rinsed thoroughly of any solution containing chlorine.

8. When an external chemical supply system is used, make certain that no siphoning of chemicals occurs when the washer-extractor is not in use. Highly concentrated chemicals can cause severe damage to stainless steel and other components within the machine. Damage of this kind is not covered by the manufacturer's warranty. Locate the pump below the washer's injection point to prevent siphoning of chemicals into the machine

# Decommissioning

## Decommissioning

In the event that the machine must be decommissioned, follow the following steps:

1. Remove the chemical injection supply system, if applicable.

- a. Have a qualified electrician disconnect power to the chemical injection supply system and the re-circulation pump at their source.
- b. Using the manufacturer's instructions, carefully remove the chemical injection supply system from the machine. Make certain that no chemicals supplies come in contact with skin or clothing.

2. Clean interior of machine, both basket and shell.

- a. Flush supply dispenser with water.
- b. Run a short rinse cycle to clean chemical residues from the interior of the machine.

3. Disconnect electrical power.

- a. Shut off main power supply at the breaker box or main control panel.
- b. Do not attempt to disconnect power supply wires from power supply. Have a qualified electrician disconnect power to machine at its source.

4. Disconnect hoses.

- a. Disconnect drain hose from sump, gutter, or drain.
- b. Turn off water supply. Disconnect individual hot and cold water inlet hoses from the machine
- c. Disconnect the compressed air

supply to the machine.

- d. Allow time for residual water in the machine to drain. Then disconnect drain hoses from the machine.
- e. Disconnect necessary plumbing on the re-circulation system, if applicable.

5. Disconnect steam hoses, if applicable

- a. Turn off steam supply and allow time for the valve to cool.
- b. Disconnect steam hose from machine.

6. Remove the machine from its foundation pad.

- a. Keep all panels in place to provide stability when moving the machine.
- b. Verify that door is closed and secure
- c. Loosen and remove anchor bolts holding the machine base to the floor
- d. Break the grout seal at each corner of the machine, using a crowbar.
- e. Place the machine on skid and bolt the frame to the skid. This will facilitate the removal of the machine on to a truck.

7. Recycle.

The manufacturer uses the highest quality material in their products so that those material may be recycled at the end of the product's service life.

